

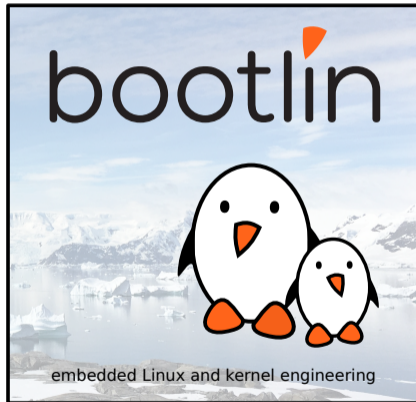

Advanced Camera Support on Allwinner SoCs with Mainline Linux

Paul Kocialkowski
paul@bootlin.com

© Copyright 2004-2022, Bootlin.
Creative Commons BY-SA 3.0 license.
Corrections, suggestions, contributions and translations are welcome!





- ▶ Embedded Linux engineer at Bootlin
 - ▶ Embedded Linux **expertise**
 - ▶ **Development**, consulting and training
 - ▶ Strong open-source focus
- ▶ Open-source contributor
 - ▶ Co-maintainer of the **cedrus** VPU driver in V4L2
 - ▶ Contributor to the **sun4i-drm** DRM driver
 - ▶ Contributing the **logicvc-drm** DRM driver
 - ▶ Developed the **displaying and rendering graphics with Linux** training
- ▶ Living in **Toulouse**, south-west of France



An Introduction to Image Capture Technology



Overview of the Digital Image Capture Chain

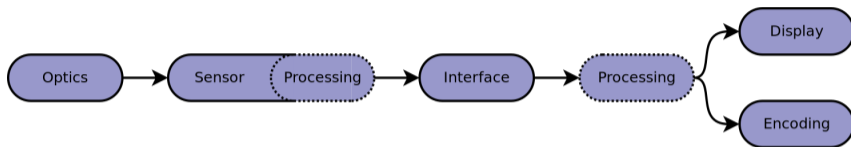

An image capture chain

- ▶ **Optics:** shape light rays
- ▶ **Sensor:** convert light to digital values
- ▶ **Interface:** transport values
- ▶ **Processing:** produce good-looking pictures
- ▶ **Display/encoding:** show/store pictures (*out of the scope of this talk*)



Processing RAW Images

Data coming from a sensor ADC needs processing:

- ▶ Data corresponds to a **bayer pattern**, not pixels
- ▶ Brightness is linear, not adapted for display
- ▶ Sensors have a non-zero **dark-level current**
- ▶ Noise is present, color is off, image looks bad

Enhancement takes place in **Image Signal Processors (ISPs)**

Three distinct domains are involved:

1. **Bayer domain**, ends with debayering step
2. **RGB domain**, ends with YUV conversion
3. **YUV domain**, ends with final picture



Image Enhancements in ISPs

Various enhancements are usually applied to the image:

- ▶ **Dead pixel correction:** discard invalid values
- ▶ **Black level correction:** remove dark level current
- ▶ **White balance:** adjust R-G-B balance with coefficients/offsets
- ▶ **Noise filtering:** remove electronic noise
- ▶ **Color matrix:** adjust colors for fidelity
- ▶ **Gamma:** adjust brightness curve for non-linearity
- ▶ **Saturation:** adjust colorfulness
- ▶ **Brightness:** adjust global luminosity
- ▶ **Contrast:** adjust bright/dark difference



Image Enhancements in ISPs

More advanced enhancements may also be applied:

- ▶ **Lens shading**: correct lens irregular brightness
- ▶ **Lens dewarp**: correct lens geometry distortion effect
- ▶ **Stabilization**: crop to remove shaking
- ▶ **Color LUT**: Translate colors with a specific style

Hardware implementations:

- ▶ ISPs embedded in sensors tend to be **simple**
 - ▶ Provide YUV data to the camera interface
- ▶ Multimedia Systems on a Chip often have an **advanced ISP**
 - ▶ Require raw bayer data on the camera interface
 - ▶ Require specific calibration data for the sensor/lens



Processing RAW Images: Illustration

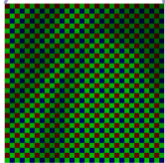
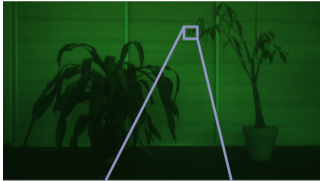

Bayer step



RGB step

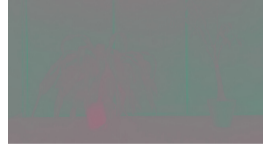

YUV step



Parameters to Adjust

Some parameters depend on the situation:

- ▶ **Focus** depends on the area of interest
- ▶ **White balance** depends on the light source(s)
- ▶ **Exposure** depends on the amount of light



Parameters to Adjust

Some parameters depend on the situation:

- ▶ **Focus** depends on the area of interest
- ▶ **White balance** depends on the light source(s)
- ▶ **Exposure** depends on the amount of light

Exposure depends on a few parameters:

- ▶ Diaphragm **aperture** (f-number)
- ▶ **Exposure time** (shutter speed)
- ▶ **Amplifier gain** (ISO number equivalent)

Advanced users will set parameters manually, with artistic implications



Automatic Parameters Control with 3A

In other cases, automatic parameters control is desirable:

- ▶ **Automatic exposition:** manage exposure time and gain (optionally diaphragm)
- ▶ **Auto-focus:** detect blurry and sharp areas, adjust with focus coil
- ▶ **Auto white balance:** detect dominant lighting and adjust



Automatic Parameters Control with 3A

In other cases, automatic parameters control is desirable:

- ▶ **Automatic exposition**: manage exposure time and gain (optionally diaphragm)
- ▶ **Auto-focus**: detect blurry and sharp areas, adjust with focus coil
- ▶ **Auto white balance**: detect dominant lighting and adjust

Implemented using 3A algorithms:

- ▶ General algorithms described in **academic literature**
- ▶ Involve a **feedback loop** system, using statistics
- ▶ Implementations are usually **hardware specific** (ISP and sensor), often considered to be the secret sauce!



Hardware Interfaces for Capture

Sensors need to transmit data:

- ▶ Analog interfaces (CVBS, etc) are mostly deprecated
- ▶ **Parallel** digital interfaces: basic, BT.656
typically used with old and low-end sensors
- ▶ **Serial** digital interfaces: MIPI CSI-2, LVDS, SDI, HiSPi
typically used with high-end sensors



Hardware Interfaces for Capture

Sensors need to transmit data:

- ▶ Analog interfaces (CVBS, etc) are mostly deprecated
- ▶ **Parallel** digital interfaces: basic, BT.656
typically used with old and low-end sensors
- ▶ **Serial** digital interfaces: MIPI CSI-2, LVDS, SDI, HiSPi
typically used with high-end sensors

Basic parallel interface:

- ▶ One TTL signal per bit, usually 8/10/12/16/24 bits width
- ▶ Pixel clock and sync signals (hsync, vsync)



Hardware Interfaces for Capture

Sensors need to transmit data:

- ▶ Analog interfaces (CVBS, etc) are mostly deprecated
- ▶ **Parallel** digital interfaces: basic, BT.656
typically used with old and low-end sensors
- ▶ **Serial** digital interfaces: MIPI CSI-2, LVDS, SDI, HiSPi
typically used with high-end sensors

Basic parallel interface:

- ▶ One TTL signal per bit, usually 8/10/12/16/24 bits width
- ▶ Pixel clock and sync signals (hsync, vsync)

MIPI CSI-2 serial interface:

- ▶ Differential pairs, using double data rate (DDR)
- ▶ One clock lane (high rates) and 1-4 data lanes



Scope and Use Case



Allwinner platforms (V3 and A83T):

- ▶ Systems on a Chip with ARM CPUs
- ▶ MIPI CSI-2 receiver
- ▶ Camera interface (CSI)
- ▶ Image Signal Processor (ISP)



Scope and Use Case: Allwinner + MIPI CSI-2 + ISP

Allwinner platforms (V3 and A83T):

- ▶ Systems on a Chip with ARM CPUs
- ▶ MIPI CSI-2 receiver
- ▶ Camera interface (CSI)
- ▶ Image Signal Processor (ISP)

Image sensors (OV8865, OV5648):

- ▶ I2C control interface
- ▶ MIPI CSI-2 transmitter
- ▶ Bayer RAW formats (10/12 bits)
- ▶ Minimal to inexistent onboard ISP

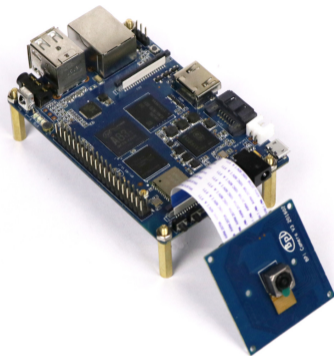

The BananaPi-M3 with OV8865
connected



Status of Allwinner Camera Support in Mainline Linux



Mainline Linux Support and Allwinner Camera Support

Allwinner platform support in mainline Linux:

- ▶ Long-time effort from the **sunxi community**, very active
https://linux-sunxi.org/Linux_mainlining_effort
- ▶ Multimedia areas are often the last missing parts
- ▶ Allwinner started contributing (more or less) very recently



Mainline Linux Support and Allwinner Camera Support

Allwinner platform support in mainline Linux:

- ▶ Long-time effort from the **sunxi community**, very active
https://linux-sunxi.org/Linux_mainlining_effort
- ▶ Multimedia areas are often the last missing parts
- ▶ Allwinner started contributing (more or less) very recently

Camera support in mainline Linux:

- ▶ `sun4i-csi` driver for first generation CSI
- ▶ `sun6i-csi` driver for second generation CSI
- ▶ Third generation CSI support is missing
- ▶ MIPI CSI-2 and ISP support was entirely missing
non-free blobs for ISP support and A80 MIPI CSI-2 in SDK



Camera Support in Linux with V4L2

Video4Linux2 (V4L2) is the subsystem/API for media support in Linux

- ▶ Supports various types of **pixel-related devices**
basically anything that is not a display or gpu
- ▶ Provides userspace with **video devices** (e.g. `/dev/video0`)
- ▶ Implements a generic **userspace API** including:
 - ▶ Format negotiation, implemented in `struct v4l2_ioctl_ops`
 - ▶ Memory management (alloc, free, mmap), implemented in `struct vb2_mem_ops`
 - ▶ A queue interface for buffers of a given type (output, capture...), implemented in `struct vb2_ops`
 - ▶ A control interface for configuration
- ▶ Good fit for **all-in-one devices** (e.g. USB UVC cameras)
assumes that a memory (DMA) interface is available



Complex systems bring the need for **more refinement**:

- ▶ Internal blocks with FIFOs
- ▶ External devices with interfaces (e.g. sensors)
- ▶ Possibility to configure each block and the topology



V4L2 Support for Complex Camera Systems : Subdevs

Complex systems bring the need for **more refinement**:

- ▶ Internal blocks with FIFOs
- ▶ External devices with interfaces (e.g. sensors)
- ▶ Possibility to configure each block and the topology

Hence the notion of **subdevs** was introduced to V4L2:

- ▶ Represent a single block (usually not DMA-capable)
- ▶ Exposed to userspace via dedicated nodes `/dev/v4l-subdev0`
- ▶ Dedicated format configuration, implemented in `struct v4l2_subdev_pad_ops`
- ▶ Dedicated stream management, implemented in `struct v4l2_subdev_video_ops`
- ▶ Called by video devices with `v4l2_subdev_call`



Subdevs need to be **parented to a v4l2 device** (controlling entity)

Simple case: the **all-in-one driver**

- ▶ A single driver may register a parent v4l2 device, a video device and subdev(s)
- ▶ The subdev can be registered directly:

```
v4l2_device_register_subdev(v4l2_dev, subdev);
```



Subdevs need to be **parented to a v4l2 device** (controlling entity)

Simple case: the **all-in-one driver**

- ▶ A single driver may register a parent v4l2 device, a video device and subdev(s)
- ▶ The subdev can be registered directly:

```
v4l2_device_register_subdev(v4l2_dev, subdev);
```

Complex case: **multiple drivers** involved

- ▶ The video device driver will typically register a v4l2 device
- ▶ Each subdev driver will register its subdev asynchronously:

```
v4l2_async_register_subdev(subdev);
```
- ▶ A driver that needs a subdev needs to identify and wait for it



V4L2 Support for Complex Camera Systems : Fwnode Graph

The fwnode graph represents the connection between different blocks:

- ▶ Typically described in device-tree with port/endpoint
- ▶ The meaning of each port is described in the device-tree bindings
- ▶ Endpoints are retrieved by the driver and parsed with a helper:

```
fwnode_graph_get_endpoint_by_id()  
v4l2_fwnode_endpoint_parse()
```

- ▶ May contain an indication of the bus type:

```
enum v4l2_mbus_type, e.g. V4L2_MBUS_CSI2_DPHY
```

- ▶ As well as bus-specific information:

```
e.g. struct v4l2_fwnode_bus_mipi_csi2
```



V4L2 Support for Complex Camera Systems : Fwnode Graph

Device-tree example for camera to MIPI CSI-2 bridge:

```
imx219: camera@10 {
    compatible = "sony,imx219";
    ...
    port {
        camera_to_bridge: endpoint {
            data-lanes = <1 2>;
            link-frequencies = /bits/ 64 <456000000>;
            remote-endpoint = <&bridge_from_camera>;
        };
    };
};
```

```
mipi_csi2: csi@1cb1000 {
    compatible = "allwinner,sun8i-v3s-mipi-csi2";
    ...
    ports {
        ...
        port@0 {
            reg = <0>;
            bridge_from_camera: endpoint {
                data-lanes = <1 2>;
                remote-endpoint = <&camera_to_bridge>;
            };
        };
        ...
    };
};
```



Async registration allows other drivers to use the subdev:

- ▶ A link between devices is described with **fwnode graph**
- ▶ An **async notifier** will match and notify when the subdev is available:

```
v4l2_async_notifier_add_fwnode_remote_subdev
```

- ▶ The async notifier can be used by the driver with a v4l2 device:

```
v4l2_async_notifier_register(v4l2_dev, notifier);
```

- ▶ Or by a subdev that needs another subdev (e.g. a bridge):

```
v4l2_async_subdev_notifier_register(subdev, notifier);
```

- ▶ A callback gives the requesting driver a `struct v4l2_subdev`



The **media controller** API provides coordination between blocks:

- ▶ Each block is an **entity** with sink/source **pads** derivated from a video device or a subdev
- ▶ Entities declare a particular function
e.g. `MEDIA_ENT_F_PROC_VIDEO_PIXEL_FORMATTER`
- ▶ **Links** between pads of entities are created by drivers, may allow userspace to enable/disable them
- ▶ Grouped in a media device (tied to a v4l2 device)
- ▶ Performs **runtime validation** for links, implemented in `struct media_entity_operations's link_validate`
- ▶ Topology is **exposed to userspace**, usually controlled with `media-ctl`:
`media-ctl -l '"sun6i-csi-bridge":1 -> "sun6i-csi-capture":0[1]'`



V4L2 Support for Complex Camera Systems : Media Controller

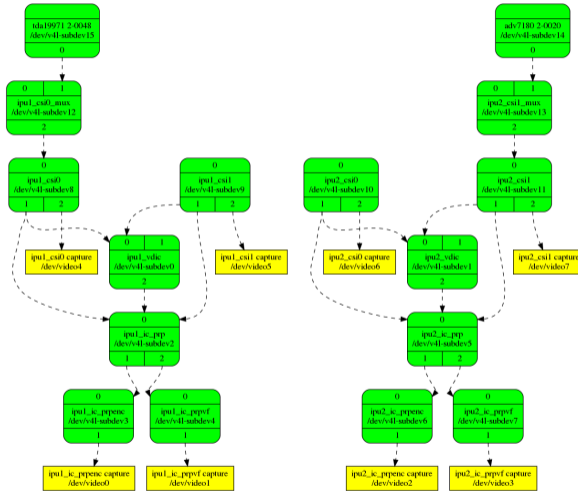

The i.MX capture driver's media topology



V4L2 Support for Image Signal Processors (ISPs)

Specific aspects related to ISPs:

- ▶ Usually have an internal pipeline with **multiple blocks**
- ▶ Parameters are **highly specific** (not a good fit for V4L2 controls)
- ▶ Provide stats **information buffers** (3A, histogram)
- ▶ Exposes one or multiple **capture interfaces**



V4L2 Support for Image Signal Processors (ISPs)

Specific aspects related to ISPs:

- ▶ Usually have an internal pipeline with **multiple blocks**
- ▶ Parameters are **highly specific** (not a good fit for V4L2 controls)
- ▶ Provide stats **information buffers** (3A, histogram)
- ▶ Exposes one or multiple **capture interfaces**

ISPs integration in V4L2:

- ▶ Processor represented by a subdev/media entity: `MEDIA_ENT_F_PROC_VIDEO_ISP`
- ▶ **Capture video devices** for pixels: queues with type `V4L2_BUF_TYPE_VIDEO_CAPTURE`
- ▶ **Meta output video devices** for parameters: queue with type `V4L2_BUF_TYPE_META_OUTPUT` with dedicated (struct) buffer type
- ▶ **Meta capture video devices** for stats: queue with type `V4L2_BUF_TYPE_META_CAPTURE` with dedicated (struct) buffer type



V4L2 Support for Image Signal Processors (ISPs): rkisp1

Example driver: **rkisp1**

- ▶ `rkisp1_isp` subdev device to coordinate
- ▶ `rkisp1_mainpath`, `rkisp1_selfpath` giving pixels, with resizers
- ▶ `rkisp1_params` taking `struct rkisp1_params_cfg`
- ▶ `rkisp1_stats` giving `struct rkisp1_stat_buffer`

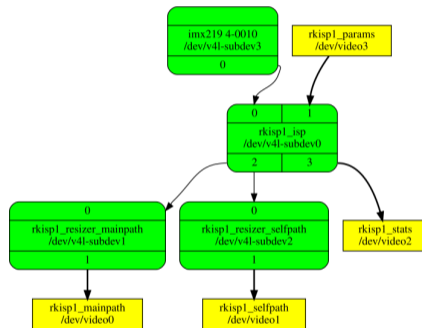

The rkisp1 media topology



Accomplished Work for Advanced Camera support on Allwinner



A31/V3 and A83T MIPI CSI-2 Support

- ▶ MIPI CSI-2 controllers feed (raw) data to the **CSI controller**
- ▶ Represented as bridges (subdevs) between CSI and the sensor
- ▶ Requires **adaptation to the CSI code** to select interface
- ▶ Needs to get sensor **pixel rate** from dedicated control: `V4L2_CID_PIXEL_RATE`
- ▶ Using a D-PHY block with the **generic Linux PHY API**
 - ▶ `phy_mipi_dphy_get_default_config` helper not accounting for DDR

A83T Support:

- ▶ **Reference source code** in Allwinner SDK:
`drivers/media/video/sunxi-vfe/mipi_csi/bsp_mipi_csi.c`
- ▶ Some **magic values** in registers (undocumented)
- ▶ D-PHY is mixed with controller registers
 - ▶ In-driver PHY provider and consumer



A31/V3 and A83T MIPI CSI-2 Support

A31/V3 Support:

- ▶ **Reference source code** in Allwinner SDK:

```
drivers/media/video/sunxi-vfe/mipi_csi/{protocol,dphy}
```

- ▶ **Documentation** available in A31 user manual
- ▶ Same D-PHY block used for MIPI DSI, in Rx mode instead of Tx
- ▶ Driver already exists for Tx, needs direction selection:
 - ▶ Describe with submode? Not a run-time decision...
 - ▶ Describe with different compatible? Same hardware block...
 - ▶ Describe with optional device-tree property



V3 and A83T MIPI CSI-2 Support: Patch Series

- ▶ First iteration sent out in October 2020
- ▶ Series later integrated with ISP work

```
arch/arm/boot/dts/sun8i-a83t.dtsi | 26 ++
arch/arm/boot/dts/sun8i-v3s.dtsi | 68 ++++
drivers/media/platform/sunxi/sun6i-csi/sun6i_csi.c | 218 ++++++-----
drivers/media/platform/sunxi/sun6i-csi/sun6i_csi.h | 65 +-
drivers/media/platform/sunxi/sun6i-csi/sun6i_video.c | 57 +-
drivers/media/platform/sunxi/sun6i-csi/sun6i_video.h | 7 +-
drivers/media/platform/sunxi/sun6i-mipi-csi2/sun6i_mipi_csi2.c | 600 ++++++
drivers/media/platform/sunxi/sun6i-mipi-csi2/sun6i_mipi_csi2.h | 117 +++++
drivers/media/platform/sunxi/sun8i-a83t-mipi-csi2/Kconfig | 11 +
drivers/media/platform/sunxi/sun8i-a83t-mipi-csi2/Makefile | 4 +
drivers/media/platform/sunxi/sun8i-a83t-mipi-csi2/sun8i_a83t_dphy.c | 92 +++++
drivers/media/platform/sunxi/sun8i-a83t-mipi-csi2/sun8i_a83t_dphy.h | 39 ++
drivers/media/platform/sunxi/sun8i-a83t-mipi-csi2/sun8i_a83t_mipi_csi2.c | 666 ++++++
drivers/media/platform/sunxi/sun8i-a83t-mipi-csi2/sun8i_a83t_mipi_csi2.h | 197 ++++++
drivers/phy/allwinner/phy-sun6i-mipi-dphy.c | 164 ++++++
25 files changed, 2633 insertions(+), 141 deletions(-)
```



ISP Support and Integration

Input/output aspects:

- ▶ ISP takes (raw) data from one of the **CSI controller(s)**
- ▶ DRAM input exists in theory but unable to make it work
- ▶ Input/interface part of CSI controller needs to be configured
- ▶ **Internal mux** routes data to ISP instead of CSI DMA
 - ▶ Impossible to switch back to CSI DMA without reboot
- ▶ **Two outputs** available: main-channel and sub-channel

Major CSI rework required:

- ▶ Separate bridge from DMA engine (subdev and video device)
- ▶ Register with ISP's v4l2/media devices for common topology
- ▶ Allow standalone use (both with and without ISP enabled):
`sun6i_csi_isp_detect` helper



ISP Support and Integration: Topology

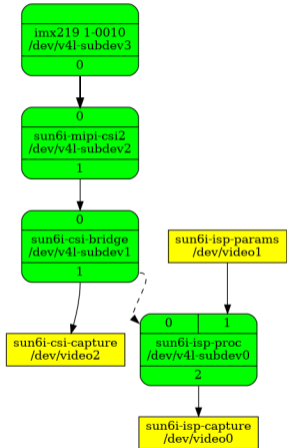

The sun6i-isp/sun6i-csi media topology

CSI components:

- ▶ sun6i-csi-bridge
- ▶ sun6i-csi-capture

ISP components:

- ▶ sun6i-isp-proc
- ▶ sun6i-isp-params
- ▶ sun6i-isp-capture

MIPI CSI-2 interface:

- ▶ sun6i-mipi-csi2
- ▶ sun8i-a83t-mipi-csi2



Parameters configure **modules of the ISP**:

- ▶ Passed via `sun6i-isp-params` video device
- ▶ uAPI structure: `struct sun6i_isp_params_config`
- ▶ Applied to next load buffer update

Supported features:

- ▶ **Bayer coefficients**, with R/GR/GB/B gain/offset:
`struct sun6i_isp_params_config_bayer`
- ▶ **2D noise filtering** (BDNF) coefficients for G and R/B:
`struct sun6i_isp_params_config_bdnf`
- ▶ Submitted to **staging** since a stable uAPI needs all features covered



ISP Driver and Integration: Patch Series

- ▶ First iteration sent out in September 2021

```
drivers/media/platform/sunxi/sun6i-csi/sun6i_csi.c | 1051 ++++++-----
drivers/media/platform/sunxi/sun6i-csi/sun6i_csi.h | 155 ++---
drivers/media/platform/sunxi/sun6i-csi/sun6i_csi_bridge.c | 895 ++++++
drivers/media/platform/sunxi/sun6i-csi/sun6i_csi_bridge.h | 64 ++
drivers/media/platform/sunxi/sun6i-csi/sun6i_csi_capture.c | 1094 ++++++
drivers/media/platform/sunxi/sun6i-csi/sun6i_csi_capture.h | 73 +++
drivers/media/platform/sunxi/sun6i-csi/sun6i_csi_reg.h | 364 +++++-----
drivers/staging/media/sunxi/sun6i-isp/sun6i_isp.c | 577 ++++++
drivers/staging/media/sunxi/sun6i-isp/sun6i_isp.h | 86 +++
drivers/staging/media/sunxi/sun6i-isp/sun6i_isp_capture.c | 759 ++++++
drivers/staging/media/sunxi/sun6i-isp/sun6i_isp_capture.h | 79 +++
drivers/staging/media/sunxi/sun6i-isp/sun6i_isp_params.c | 571 ++++++
drivers/staging/media/sunxi/sun6i-isp/sun6i_isp_params.h | 53 ++
drivers/staging/media/sunxi/sun6i-isp/sun6i_isp_proc.c | 598 ++++++
drivers/staging/media/sunxi/sun6i-isp/sun6i_isp_proc.h | 61 ++
drivers/staging/media/sunxi/sun6i-isp/sun6i_isp_reg.h | 275 ++++++
drivers/staging/media/sunxi/sun6i-isp/uapi/sun6i-isp-config.h | 43 ++
51 files changed, 8702 insertions(+), 1808 deletions(-)
```



Future Work and Improvements



Remaining Features to Implement

Roadmap for ISP driver completeness:

- ▶ Support **more platforms** (at least A83T)
- ▶ Declare **hardware revisions** (modules availability):
`media_dev->hw_revision`
- ▶ Support for **stats** (hist/ae/awb/af/afs)
- ▶ Support for **sub-channel, scaling and rotation**
- ▶ **Complete uAPI** that describes all modules
- ▶ Support for **all available modules**
 - ▶ Start with black level correction, color matrix and gamma
- ▶ Userspace **3A algorithms** support



Integration with libcamera



- ▶ Community-driven project for advanced camera support: **libcamera**
- ▶ Provides **abstraction** for applications, GStreamer, Android
- ▶ Implements **complex pipeline support**
- ▶ Implements **hardware-specific 3A algorithms**
- ▶ Good fit for Allwinner A31 ISP userspace support

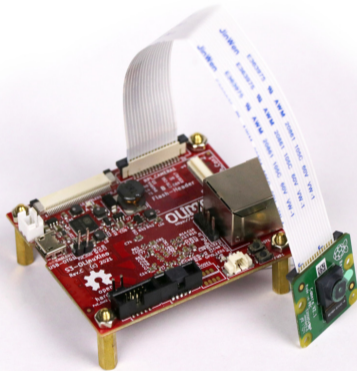

Olimex announced the S3-OLinuXino, with a RPi-compatible MIPI CSI-2 connector!

Questions? Suggestions? Comments?

Paul Kocialkowski
paul@bootlin.com

Slides under CC-BY-SA 3.0
<https://bootlin.com/pub/conferences/>



Extra Slides



Optical systems have multiple elements and purposes:

- ▶ **Lens** to make light converge towards sensor surface
 - ▶ **Focal length** (f) indicates the amount of convergence
 - ▶ Sets the angle of view, results in magnification/zoom effect
 - ▶ Optional moving elements to define focus plane
- ▶ Optional **focus coil** to electrically control focus adjustment
- ▶ Optional **diaphragm** to control aperture
 - ▶ **F-number** (e.g. $f/1.8$) indicates how open the diaphragm is
 - ▶ Aperture decreases with f-number (diaphragm closes)



Camera Optical Systems: Illustration

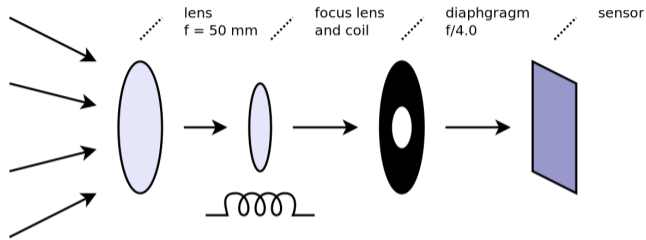

Camera optical system



Diaphragm aperture variation (CC BY-SA 3.0, KoeppiK, Wikimedia Commons)



Image Sensors

Components of an image sensor:

1. Color Filter Array (CFA) following a **Bayer pattern** (R/G/G/B)
2. Photo-sensitive cells (**photosites**) in CMOS or CCD technology
3. **Amplifier and ADC** to produce digital values
 - ▶ Generally 8, 10 or 12-bit data
4. Configurable **shutter speed** (exposure time)
5. **Clocks and timings** for frame rate
 - ▶ Capture cycle repeatedly following precise timings
 - ▶ External clock reference for internal PLLs
 - ▶ Limits exposure time
6. **Processing** (more or less advanced)
7. Control and **configuration** interface
 - ▶ Usually configured via I2C or SPI
8. Data **transmission** interface



Image Sensors: Illustration

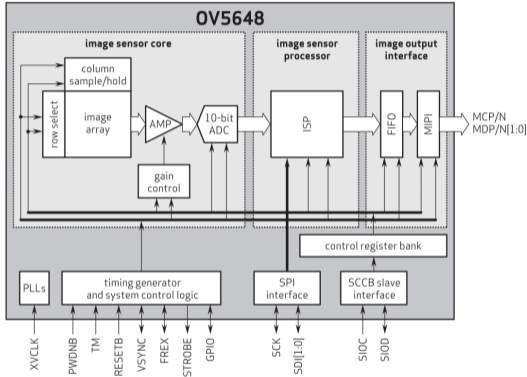

OV5648 block diagram (*Omnivision*)

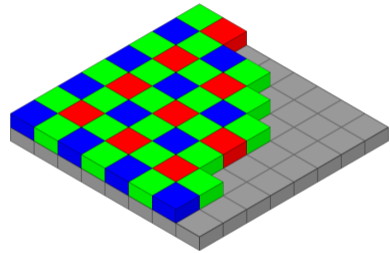

Bayer pattern (*CC BY-SA 3.0, Cburnett, Wikimedia Commons*)

